

Leaffield

Engineering Limited

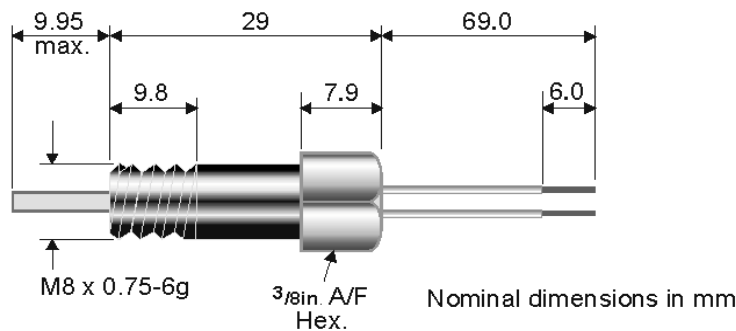

PROTRACTOR C891541A

GENERAL DATA

Stroke	9.70mm min. to 9.95mm max.
Piston diameter	2.45mm max.
Weight	11g
Maximum tightening torque	1.5Nm
Materials	Brass body, stainless steel piston
Operating temperature	-40 °C to +80 °C (for temperature/life data please consult LEL)
Life (20°C)	15 years
HSE classification	Non-explosive
Transport	Normal parcel post

OPERATION

On firing, the piston will actuate at high velocity. There is no release of gas and no fragmentation.

PERFORMANCE

Guaranteed minimum work output	3.0J
Typical function time	5ms
Available thrust (start of stroke)	1.0kN
Available thrust (end of stroke)	0.5kN

ELECTRICAL CHARACTERISTICS

Circuit resistance	1.85 ±0.55Ω
Maximum no fire current	0.2A
Recommended fire current	0.9A
Maximum test current	0.01A
Insulation resistance	>150MΩ at 100V DC
Earth monitoring voltage	250V DC (max.) continuous
Electrostatic resistance (pin to case)	Withstands discharge from 150pF capacitor charged to 2kV with 330Ω resistor in series in accordance with IEC1000-4-2 (level 1). For protection to higher ESD levels please consult LEL.