

Leaffield

Engineering Limited

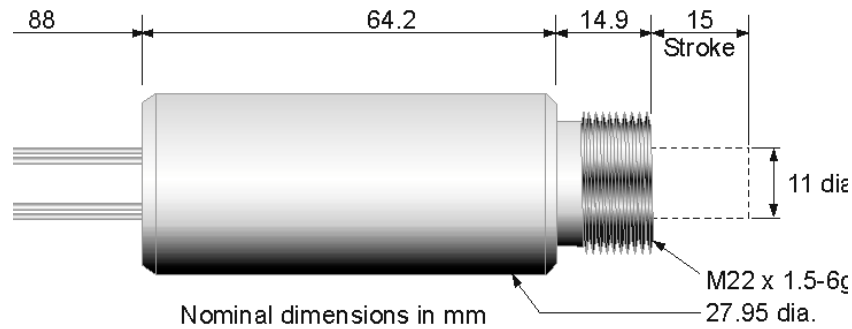

PROTRACTOR D95-150/1

GENERAL DATA

Stroke	15mm
Piston diameter	11mm
Mass	300g
Materials	Stainless steel body, hardened tempered tool steel piston
Operating temperature	-40°C to +100°C
Storage temperature	-30°C to +70°C
Life (20°C)	10 years (minimum)
HSE classification	Non-explosive
Net explosive content	600mg maximum
Transport	Normal parcel post

FEATURES

This device incorporates a dual firing system

OPERATION

On firing of either or both circuits, the piston will actuate at high velocity. There is no release of gas and no fragmentation

PERFORMANCE

Minimum work output	330J
Typical function time	4ms from initiation of firing pulse
Available thrust (at start of stroke)	40kN
Available thrust (at end of stroke)	5kN

ELECTRICAL CHARACTERISTICS

Nominal Circuit Resistance	0.6 Ω
Maximum no fire current	0.65A
Recommended fire current	2A
Maximum test current	0.01A
Insulation resistance	>100MΩ at 100V DC

Note: This device may be modified to comply with customer requirements as performance depends on loading conditions.

Leaffield Engineering Limited

Design, Manufacture & Through Life Support Specialists

Leaffield Way, Leaffield, Corsham, Wiltshire SN13 9SS
Telephone: 01225 810771 Fax: 01225 810614



REF NO: 1010

SHT 1 OF 3

ISSUE NO: 1

ISSUE DATE: 14/12/95

PRODUCT SAFETY DATA SHEET (FOR PRODUCTION UNITS)

1. PRODUCT NOMENCLATURE

PROTRACTOR (D95-150/1)

2. USES

To provide an actuating function.

3. HAZARDOUS INGREDIENTS

<u>Material</u>	<u>Hazard</u>	<u>Nominal Per Unit</u> <u>mg</u>
PROPELLANT	Deflagration	600 max.

Note: Deflagration effects are totally contained within the body.

4. PHYSICAL PROPERTIES, CHEMICAL PROPERTIES, SENSITIVENESS CHARACTERISTICS

Physical Properties

Appearance Stainless Steel Body to BS 2S.145. Hazardous material contained within steel body with encapsulation material to fully seal.

Chemical Properties

Incompatible with acids and alkalis.

Sensitiveness Characteristics

Sensitive to flame: Excessive heat may cause operation.

Conditions to avoid: Open flame, electric spark, or charge exceeding the specified no-fire current, prolonged exposure to temperatures above 125°C.

RJF95025

Leaffield Engineering Limited

Design, Manufacture & Through Life Support Specialists

Leaffield Way, Leaffield, Corsham, Wiltshire SN13 9SS

Telephone: 01225 810771 Fax: 01225 810614



REG. No. FM 29682

SHT 2 OF 3

5. HEALTH HAZARDS

Precautions

1. Forceful protrusion of the piston rod (Ø11mm) may result if an attempt is made to tamper with or dismantle these devices before use.
2. Hazard may result if an attempt is made to dismantle these devices after use, due to the release of high pressure gas.
3. In an unpackaged condition inadvertent operation may result in hazard caused by forceful protrusion of the piston rod.

6. FIRE AND EXPLOSION

These devices will operate in the presence of excessive heat, typically above 125°C.

Hazardous decomposition: None. No outgassing produced.

7. STORAGE PRECAUTIONS

Store in original packaging in well ventilated, dry store.

Storage life in original packaging is 10 years at 20°C.

8. TRANSPORT, PACKAGING AND LABELLING

These items are classified Non-Explosive as a provisional classification in the package supplied. Any onward shipment must be within this package.

Transport for development batches by company transport.

9. PROTECTION INFORMATION

Facial protection during installation.

10. DISPOSAL INSTRUCTIONS

Used or life expired devices, may be returned to Leaffield Engineering Ltd for disposal.

RJF95025

Leaffield Engineering Limited

Design, Manufacture & Through Life Support Specialists

Leaffield Way, Leaffield, Corsham, Wiltshire SN13 9SS
Telephone: 01225 810771 Fax: 01225 810614



REG. No. FM 29682

SHT 3 OF 3

11. EMERGENCY ACTION

Fire represents the principal risk to safety due to the likelihood of operation. If possible and without risk to safety the devices should be removed from the immediate location of a fire.

If the packaging is burning, do not attempt to fight fire - Possible Projection Hazard.

Call emergency services. Evacuate the immediate area.

12. ADDITIONAL INFORMATION

Refer to Leaffield Engineering Ltd

Tel 01225 810771

RJF95025